



# Sherex Seal 2<sup>®</sup> Rivet Nut

The Next Generation of Sealing Technology



## *Product Applications:*

- When there is a need to seal a rivet nut and the part has to withstand a finish baking process
- If you have a problem with auto fluids damaging your rivet nut seal
- When PVC is not sealing to the high pressure you need

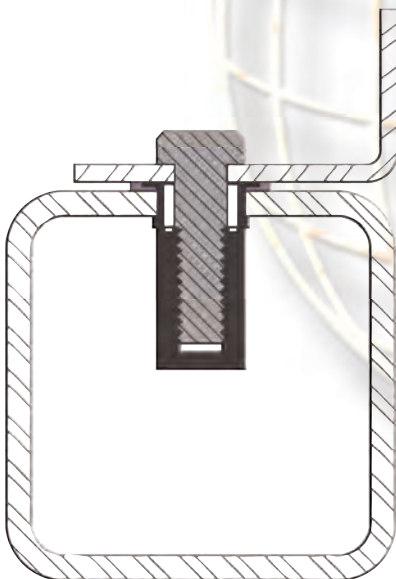

## *Product Information:*

Sherex Fastening Solutions is proud to introduce the Sherex Seal 2<sup>®</sup> head sealant for rivet nuts. This product has been designed for use in applications where it is necessary to seal fluid or air leakage from under the head. The Seal 2<sup>®</sup> provides greater performance over conventional sealing materials such as PVC foam.

## *Seal 2<sup>®</sup> Product Benefits:*

- Resistant to automotive fluids
- Can withstand temperatures up to 150°C
- Has been pressure tested to 160 psi of back-side pressure with no leakage
- Seal 2<sup>®</sup>-processed rivet nuts can be installed into any finished material
- Seal 2<sup>®</sup> can pass through a paint bake or other baking process for up to 30 minutes with no reduction in sealing capabilities
- Can be applied to any standard rivet nut

*All of these advantages make Seal2<sup>®</sup> a superior alternative to other sealing methods.*